



www.precisionarmament.com

Precision Armament
Wellsville, NY 14895
PH: 1-800-724-3802
FX: 1-585-593-5637

MADE
IN THE USA



M4-72 Severe-Duty™ AK-47 Muzzle Brake Installation Guide

IMPORTANT: READ INSTRUCTIONS COMPLETELY BEFORE INSTALLATION.

WARNING: MAKE SURE FIREARM IS UNLOADED BEFORE INSTALLATION. VISUALLY INSPECT CHAMBER, MAGAZINE, AND FIRING MECHANISM TO BE CERTAIN NO AMMUNITION IS IN THE FIREARM.

NOTE: Two **Crush Springs** are included (1 Install, 1 Spare), only one should be used during final installation to eliminate play between brake and barrel. It is **important** to follow the instructions in order and perform a dry run installation of the brake on the barrel **without** the crush spring to determine final installation spacing. Failure to do this and over-tightening brake onto the spring will cause permanent deformation and a loss in spring preload.

INSTALLATION: While depressing muzzle device detent pin on front sight post, thread muzzle brake onto barrel (Do not include crush spring). Thread brake hand tight until the back of the brake stops against front sight post. Next release detent pin

and thread brake off barrel until the detent pin drops into the first available position. Carefully note this position for final installation. Next remove muzzle brake and place crush spring over threads against sight post. Thread brake back onto barrel to the same position that was noted. **Caution:** Do not thread brake past this position. Over-tightening brake onto crush spring may result in loss of spring preload.

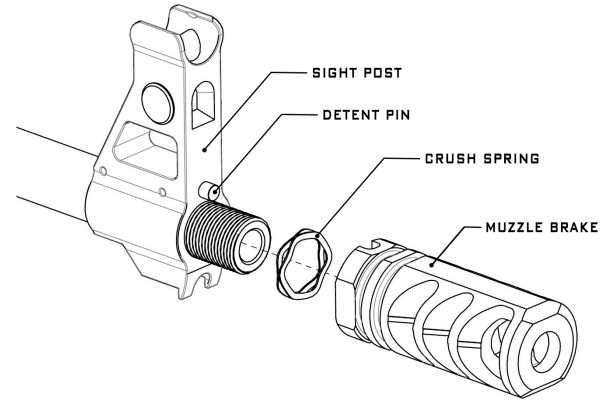

IMPORTANT: THIS MUZZLE DEVICE IS DESIGNED ONLY TO BE USED ON THE AK-47 RIFLE CHAMBERED IN 7.62MM CALIBER OR SMALLER.

CAUTION: This device operates by redirecting high-pressure gases at the muzzle. As a result, debris, gas, and propellant particles can be propelled back towards the shooter or nearby observers. ALWAYS WEAR EYE AND EAR PROTECTION WHEN SHOOTING OR OBSERVING.

Copyright © 2015 Precision Armament, DOC -A012

www.precisionarmament.com

Precision Armament
Wellsville, NY 14895

PH: 1-800-724-3802
FX: 1-585-593-5637